



Parallels Mac Management for Microsoft SCCM

Deployment Guide and Pre-Install Checklist

v6.1

Parallels International GmbH
Vordergasse 59
8200 Schaffhausen
Switzerland
Tel: + 41 52 672 20 30
parallels.com

Copyright © 1999-2017 Parallels International GmbH. All rights reserved.

This product is protected by United States and international copyright laws. The product's underlying technology, patents, and trademarks are listed at parallels.com/about/legal.

Microsoft, Windows, Windows Server, Windows Vista are registered trademarks of Microsoft Corporation.

Apple, Mac, the Mac logo, OS X, macOS, iPad, iPhone, iPod Touch are trademarks of Apple Inc., registered in the US and other countries.

Linux is a registered trademark of Linus Torvalds.

All other marks and names mentioned herein may be trademarks of their respective owners.

Contents

Introduction.....	4
Glossary.....	4
Solution Overview	5
Components Overview	5
Deployment Configurations	7
Deploying to a Standalone SCCM Site	7
Installing Parallels Console Extensions	7
Installing Parallels Configuration Manager Proxy	8
Deploying to a Primary Site with Secondary Sites	8
Deploying to a Primary Site.....	8
Deploying to a Secondary Site	8
Deploying to a Central Administration Site	9
Deploying Parallels NetBoot Server	10
macOS Software Update Management	12
Required Components	12
Download Updates from Apple Servers.....	13
Download Updates from a Local Update Server.....	14
Restrict Which Updates a Mac User Can Install	14
Apple DEP Support	16
Required Components	16
One MDM Server Serving One SCCM Site	17
Remote Lock and Wipe	19
Required Components	19
Wipe a DEP-Enabled Mac Computer	20
Wipe a Non-DEP Mac Computer.....	20
Pre-Installation Checklist.....	22
Index.....	25

CHAPTER 1

Introduction

This guide is for network and Microsoft System Center Configuration Manager (SCCM) administrators who are planning to deploy Parallels® Mac Management for Microsoft® SCCM in their organization. This guide assumes that the reader has knowledge of SCCM, its architecture, and its components.

The guide does not cover topics related to user rights and other system requirements. This information can be found in the Parallels Mac Management Administrator's Guide at parallels.com/products/mac-management/support/.

In This Chapter

Glossary	4
Solution Overview	5
Components Overview	5

Glossary

SMS	System Management Server (the core component of System Center Configuration Manager)
CAS	Central Administration Site
DP	SCCM Distribution Point
MP	SCCM Management Point
Admin Console	SCCM Administrative Console
WDS	Windows Deployment Services
BITS	Background Intelligent Transfer Service
Parallels Mac Management	Parallels Mac Management for Microsoft SCCM
Proxy	Parallels Configuration Manager Proxy
Extensions	Parallels Configuration Manager Console Extensions
NetBoot	Parallels NetBoot Service
SUP	Parallels OS X® Software Update Point
WSUS	Windows Server Update Services
MDM Server	Parallels MDM Server
APNs	Apple® Push Notification Service

Apple DEP	Apple Device Enrollment Program. On diagrams in this guide, it also refers to the Apple DEP website.
MDM	Mobile Device Management
Mac Client	Parallels Mac Client



Represents a Mac® with Parallels Mac Client installed.



Represents a Windows computer with SCCM and/or Parallels Mac Management components installed.

Solution Overview

Parallels Mac Management is a software plug-in that extends Microsoft System Center Configuration Manager (SCCM) with the ability to fully manage macOS® systems. With Parallels Mac Management, you can manage Mac and Windows computers using SCCM as your only management system.

Components Overview

Parallels Mac Management consists of the following components.

Parallels Configuration Manager Proxy: A Windows service application that acts as a proxy between SCCM and Mac computers. The application must be installed on a computer running Windows Server 2008 SP2 or later.

Parallels Configuration Manager Console Extensions: A set of dynamic libraries that extends the Configuration Manager console with user interface elements, allowing you to manage Mac computers. This component must be installed on the computer where the Configuration Manager console is installed.

Parallels NetBoot Server: NetBoot is a technology from Apple that enables Mac computers to boot from a network. You must install this component if you plan to deploy macOS images on Mac computers.

Parallels OS X Software Update Point: Allows you to manage Apple software updates (patches) for macOS using the native SCCM functionality. The component requires Windows Server Update Services (WSUS) and must be installed on the same server as WSUS.

Parallels MDM Server: Enables you to deploy new Mac computers and enroll them in SCCM using the Apple Device Enrollment Program (Apple DEP). It is also used to remotely wipe and lock a Mac computer if it's lost or stolen.

Parallels Mac Client: A client application that enables communication between a Mac computer on which it is installed and Parallels Configuration Manager Proxy. The client inventories hardware and software installation information, enables the automated installation of software packages and security patches, and is used to apply compliance policies.

CHAPTER 2

Deployment Configurations

This chapter describes various Parallels Mac Management deployment configurations.

In This Chapter

Deploying to a Standalone SCCM Site	7
Deploying to a Primary Site with Secondary Sites	8
Deploying to a Central Administration Site.....	9
Deploying Parallels NetBoot Server.....	10

Deploying to a Standalone SCCM Site

The diagram below represents a standalone SCCM installation. The arrow lines represent communication channels between Parallels Mac Management and SCCM components.

Figure 1: Deployment to a standalone SCCM site

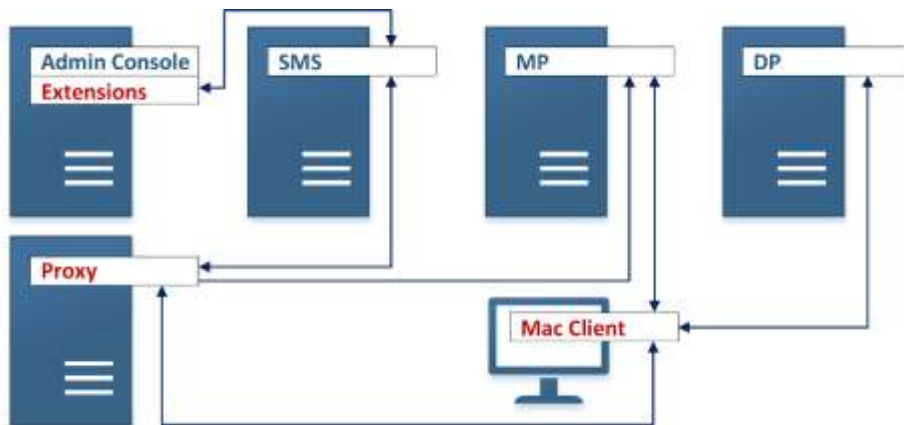

The above diagram shows each SCCM and Parallels Mac Management component installed on a separate computer. More often than not, your SCCM deployment will have several components that coexist on the same computer.

Installing Parallels Console Extensions

A standalone SCCM site would have at least one computer with SCCM Administrative Console (Admin Console) installed. It could be installed on the same server that has the System Management Server (SMS) provider installed, or on a separate computer. *You must install*

Parallels Mac Management Extensions (Extensions) on a computer that has the Admin Console installed.

Installing Parallels Configuration Manager Proxy

Parallels Configuration Manager Proxy (Proxy) can be installed on any computer that resides within SCCM site boundaries and can establish a connection to the server hosting the SMS provider. In Figure 1 (Page 7), Proxy is installed on a separate computer. In most cases, installing Proxy on a server that has the SMS provider installed (Figure 2 below) is recommended.

Figure 2: Proxy installed on the SMS server

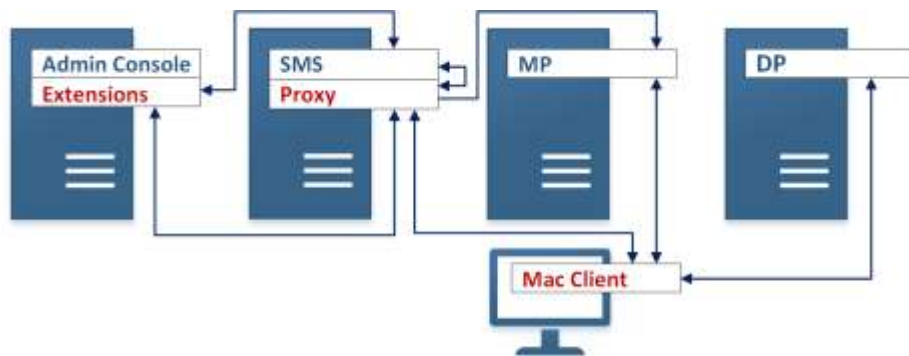

Deploying to a Primary Site with Secondary Sites

If a primary site in your SCCM installation has secondary sites, you may deploy Parallels Mac Management to the primary site or secondary sites.

Deploying to a Primary Site

When deploying Parallels Mac Management to a primary site, follow the same procedure as described in Deploying to a Standalone SCCM Site (Page 7).

Deploying to a Secondary Site

Proxy should be deployed to all secondary sites. *While this is not required, it is highly recommended.*

Deploying Proxy to all secondary sites has the following benefits:

- Allows more efficient use of bandwidth. If Proxy is not installed in a secondary site, Parallels Mac Clients in that site will have to communicate with Proxy in the primary site.
- Simplifies manual Mac Client enrollment. If Proxy is not installed in a secondary site and you try to manually enroll Mac Clients, you will have to use Active Directory (AD) credentials that have client enrollment privileges assigned in the primary site.

Figure 3: Secondary site with Parallels Configuration Manager Proxy installed

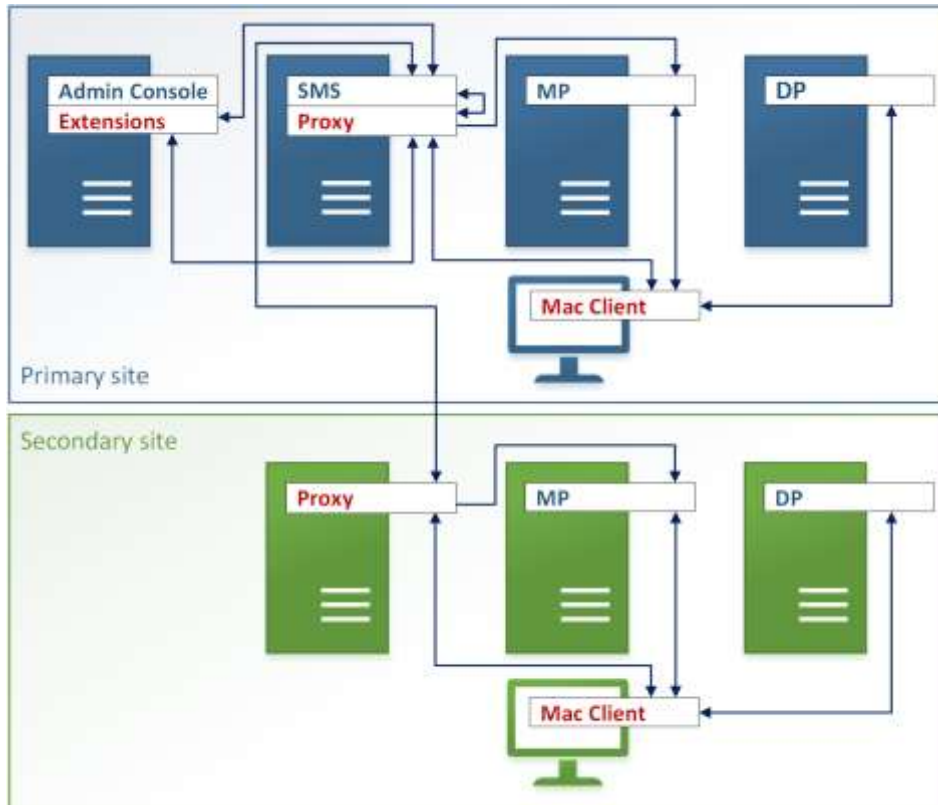

Deploying to a Central Administration Site

The only additional step to perform when deploying Parallels Mac Management in a Central Administration Site (CAS) environment is to install Parallels Console Extensions on the computer hosting the CAS Configuration Manager Console. However, this step is optional.

The following features are not supported by Parallels Console Extensions when Parallels Mac Management Extensions are installed on a CAS:

- Configuration of Parallels Network Discovery
- Retrieval of escrowed FileVault® 2 personal keys
- macOS image deployment functionality

Figure 4: Deploying Parallels Mac Management in a CAS environment

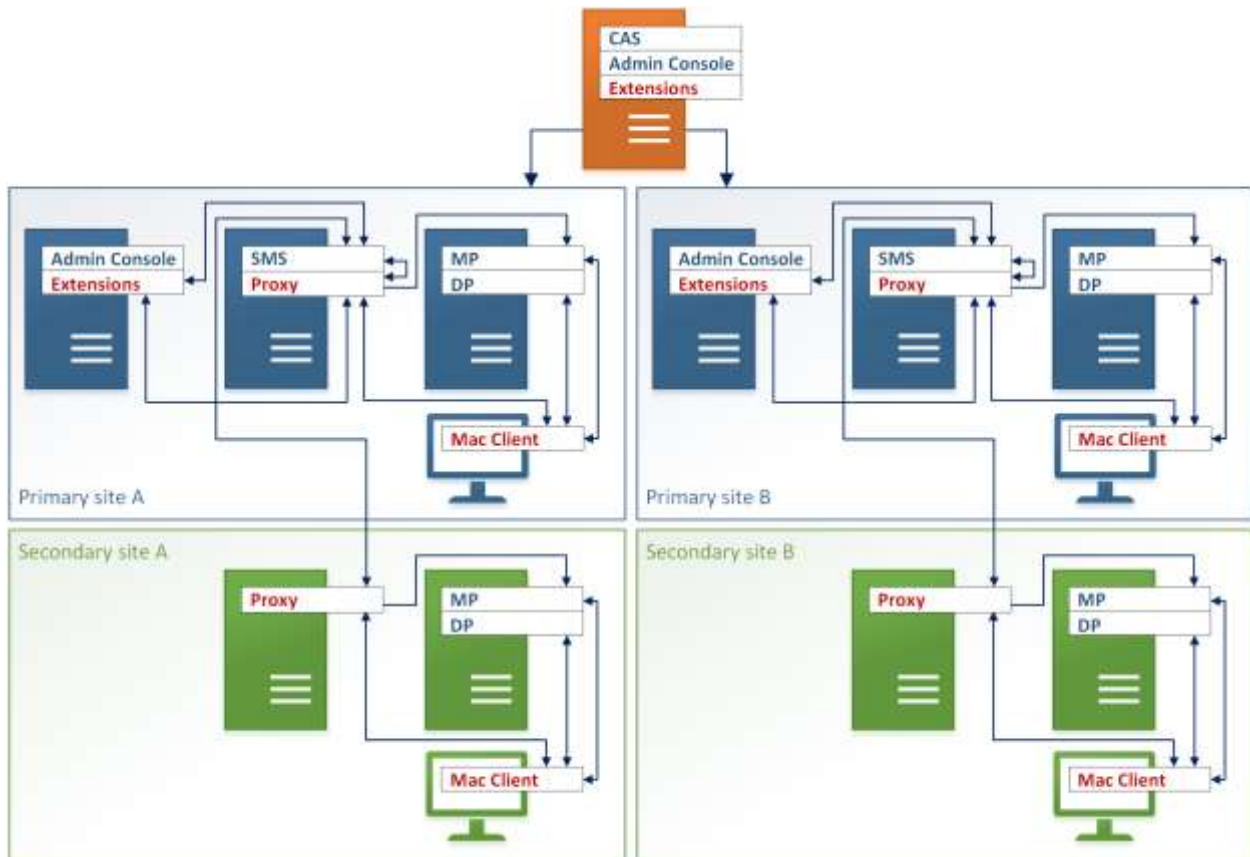

Deploying Parallels NetBoot Server

NetBoot is a technology from Apple that enables Mac computers to boot from a network. You must install this component if you plan to deploy macOS images on Mac computers.

The server on which Parallels NetBoot Server (NetBoot) will be installed must meet the following requirements:

- The SCCM Distribution Point (DP) role is installed on this server.
- Windows Deployment Service (WDS) is installed and running. If WDS and DHCP are both installed on this server, the "Do not listen on port 67" option must be selected in the WDS service properties.
- The server is a PXE service point.
- BITS 4.0 is installed. Background Intelligent Transfer Service (BITS) transfers files (downloads or uploads) between a client and a server and provides progress information related to the transfers.

These requirements remain the same for any SCCM deployment configuration, whether it's a standalone, primary, or secondary site deployment.

Figure 5: Deploying NetBoot



CHAPTER 3

macOS Software Update Management

Parallels Mac Management allows you to manage macOS software updates (patches) using the native SCCM functionality. Using this functionality, you can import information about available macOS software updates into SCCM and then deploy the updates to Mac computers in your organization.

In This Chapter

Required Components.....	12
Download Updates from Apple Servers.....	13
Download Updates from a Local Update Server.....	14
Restrict Which Updates a Mac User Can Install.....	14

Required Components

Windows Server Update Services (WSUS): Windows Server Update Services (WSUS) must be installed and configured for local publishing of updates. Installation instructions are available at the following location:

`msdn.microsoft.com/en-us/library/bb902479`

On the web page, refer to the "To set up the update server for locally-published content" section.

Parallels OS X Software Update Point: This is a component of Parallels Mac Management that enables macOS patch management in SCCM. It must be installed on a computer where WSUS is installed.

Download Updates from Apple Servers

This is the default configuration. It is the simplest scenario in which macOS update catalogs and packages are downloaded from Apple servers over the Internet.

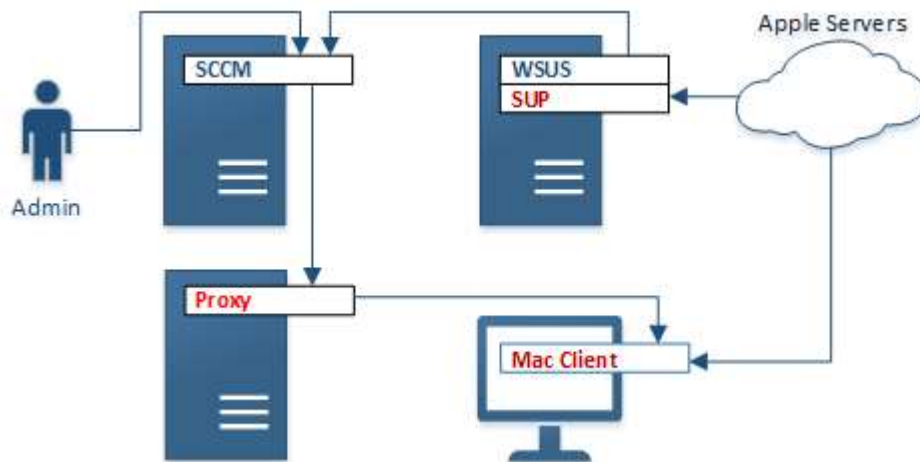

When this scenario is used, macOS updates are installed on Mac computers as follows:

- 1 Parallels OS X Software Update Point (SUP) downloads macOS update catalogs from Apple and imports them into WSUS.
- 2 WSUS is synchronized with SCCM.
- 3 The SCCM administrator deploys updates to Mac computers.
- 4 Mac computers download deployed updates from the Apple servers, after which the updates are silently installed on them.
- 5 A Mac user can check for updates using the standard macOS functionality and install any of the available updates.

Download Updates from a Local Update Server

This configuration allows you to use a local update server to host macOS update catalogs and update packages.

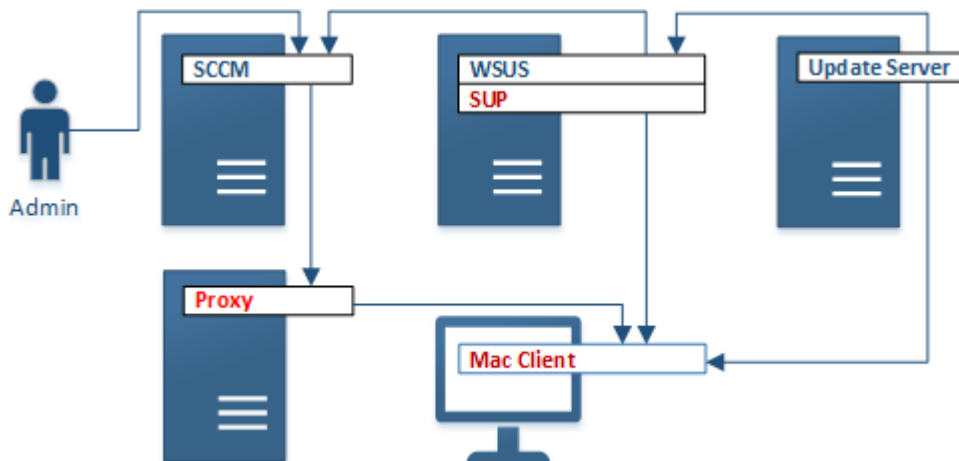

When this scenario is used, macOS updates are installed on Mac computers as follows:

- 1 Parallels OS X Software Update Point (SUP) downloads macOS update catalogs from the local update server (Update Server) and imports them into WSUS.
- 2 WSUS is synchronized with SCCM.
- 3 The SCCM administrator deploys updates to Mac computers.
- 4 Mac computers download update catalogs from Parallels OS X Software Update Point and then download update packages from the local update server.
- 5 The deployed updates are silently installed on a Mac.
- 6 A Mac user can check for updates using the standard macOS functionality and install any of the available updates. Please note that the OS X Software Update service will use the update catalogs that were downloaded from Parallels OS X Software Update Point, not the Apple servers. Update packages will also be downloaded from the local update server.

Note: To use this configuration, you need a local update server (Update Server). Parallels Mac Management does NOT include this functionality. You will have to use the Apple macOS Server or a third-party software to act as a local update server.

Restrict Which Updates a Mac User Can Install

This configuration allows you to restrict which updates a Mac user can see and install. Note that this configuration can use Apple servers or a local update server.

When this scenario is used, macOS updates are installed on Mac computers as follows:

- 1** Parallels OS X Software Update Point downloads macOS update catalogs from Apple servers or the local update server (depending on the configuration) and imports them into WSUS.
- 2** WSUS is synchronized with SCCM.
- 3** The SCCM administrator deploys updates to Mac computers.
- 4** Mac computers download full update catalogs from the Apple servers or the Parallels OS X Software Update Point (depending on the configuration). The catalogs are then filtered to include only the updates that were deployed in SCCM. If a Mac user now checks for available updates using the standard macOS functionality, they will not be able to see and install hidden updates.
- 5** Mac computers download update packages from the location specified in a catalog (Apple servers or a local update server).
- 6** The deployed updates are silently installed on a Mac.
- 7** If a Mac user checks for updates using the standard macOS functionality, they will see only the updates that were deployed (or none at all if the updates have already been installed on this Mac).

Apple DEP Support

The Apple Device Enrollment Program (DEP) provides a fast, streamlined way to deploy corporate-owned Mac computers purchased directly from Apple or through Apple Authorized Resellers. Parallels Mac Management supports Apple DEP and provides you with the ability to automatically enroll new Mac computers in SCCM during the initial device setup procedure.

In This Chapter

Required Components.....	16
One MDM Server Serving One SCCM Site	17

Required Components

Parallels MDM Server: An MDM server is a required component in a Mobile Device Management implementation. Parallels MDM Server implements management features for Mac computers and makes them available in SCCM through Parallels Mac Management integration.

A Parallels MDM Server is linked to your organization's account on the Apple DEP website. To set up an MDM server, your organization must be enrolled in Apple Deployment Programs as described in the Apple DEP guide: apple.com/business/docs/DEP_Guide.pdf.

The computer on which you'll be installing Parallels MDM Server must meet the following requirements:

- Must be accessible from the server where the Parallels Proxy is installed.
- Must be accessible from the Internet.
- For increased security, the server should be located in DMZ.

Parallels MDM Server is installed using the Parallels Mac Management Installation Wizard. After the installation, it must be configured using the Parallels MDM Server Configuration Wizard, which starts automatically after the installation. (You can also launch the configuration wizard manually from the Start menu.)

Parallels DEP Service: Parallels DEP Service is a Windows service that is installed automatically when you install the Parallels Proxy component on a primary SCCM site (i.e. both the DEP Service and Parallels Proxy are installed on the same server). The Parallels DEP service communicates with the Apple DEP website and the local Parallels MDM Server. It is responsible for obtaining the list of Mac computers assigned to the virtual MDM server on the Apple DEP website and assigning device enrollment profiles.

One MDM Server Serving One SCCM Site

This deployment scenario uses one Parallels MDM Server serving one SCCM site.

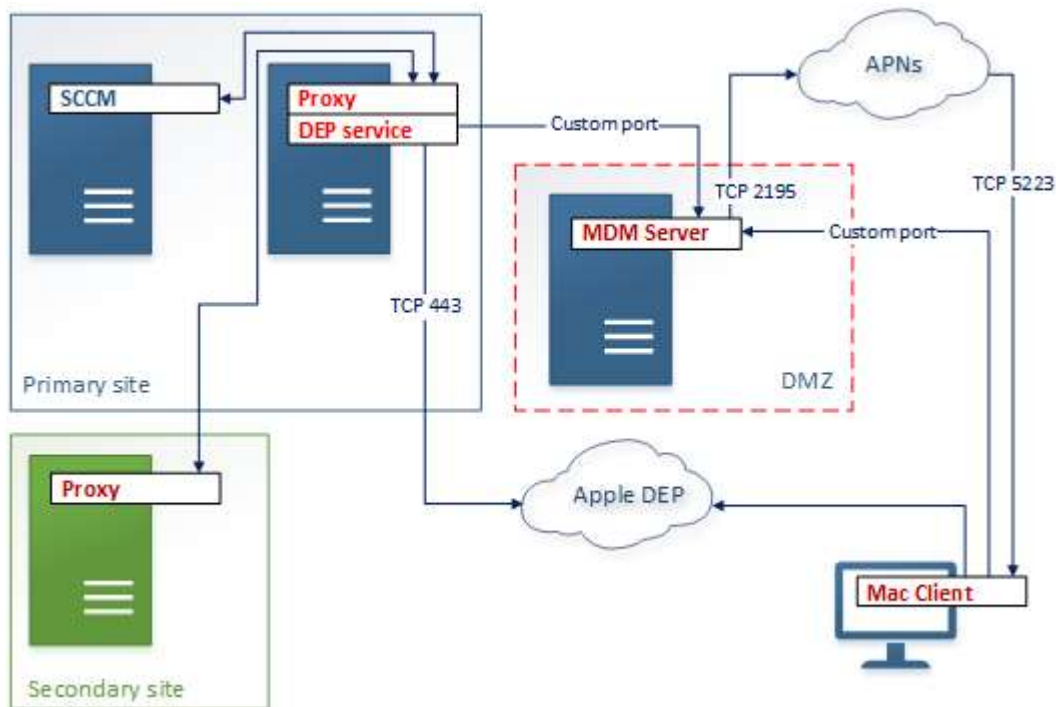

On the diagram above:

- The local Parallels DEP service is linked to the Parallels MDM Server. The link is configured in the SCCM console.
- The local Parallels DEP service is also linked to your organization's account on the Apple DEP website. This essentially links the SCCM site to Apple DEP. The link is configured in the SCCM console and the Apple DEP website. The process involves obtaining an X.509 certificate from the local server, uploading it to the Apple DEP website, and using it to create a virtual MDM server. Finally, a token is obtained from the Apple DEP website and added to the local server, thus linking the local DEP service and the virtual MDM server.
- The Parallels MDM Server uses Apple Push Notification Service (APNs) to send push notifications for MDM functions, such as Parallels Mac Client push installation and some others. Establishing this communication is one of the steps you have to complete when you run the Parallels MDM Server Configuration Wizard. The process involves obtaining a certificate signing request from Parallels My Account, then uploading it to the Apple Push Certificates Portal and obtaining an APNs certificate file from it. Finally, the certificate file is added to the Parallels MDM Server, thus enabling APNs functions on it.

Port numbers that are specified on the diagram above (e.g. TCP 443 and TCP 2195) are used to communicate with Apple services and cannot be changed. Port numbers that are labeled as "Custom port" are configured when you run the Parallels MDM Server Configuration Wizard. There are no default port numbers, so you have to select them yourself according to your requirements. Please also see Table 1 below for the list of ports shown on the diagram. All of these ports must be opened for communication.

Table 1: Communication ports used in Parallels Mac Management DEP/MDM deployment

Source	Destination	Port	Details
Server hosting Parallels Proxy and DEP service	Apple DEP service mdmenrollment.apple.com	TCP 443	Used by the Apple Device Enrollment Program service
Parallels MDM Server	Apple Push Notification Service (APNs) gateway.push.apple.com	TCP 2195	Used to send notifications to APNs
Mac computer	Apple Push Notification Service (APNs) gateway.push.apple.com	TCP 5223	The standard port to communicate with APNs
Server hosting Parallels Proxy and DEP service	Parallels MDM Server	Custom	You select a port number when you configure Parallels MDM Server
Mac computer	Parallels MDM Server	Custom	You select a port number when you configure Parallels MDM Server

Remote Lock and Wipe

When a Mac is lost or stolen, the leak of stored confidential information may lead to severe business risks. Parallels Mac Management provides you with the ability to remotely lock and wipe a Mac if it's lost or stolen.

In This Chapter

Required Components.....	19
Wipe a DEP-Enabled Mac Computer	20
Wipe a Non-DEP Mac Computer	20

Required Components

Remote wiping of Mac computers is done via the Mobile Device Management (MDM) enrollment. Parallels Mac Management uses MDM enrollment as part of the Apple DEP support (page 16). If you are using Apple DEP in SCCM, all necessary services should be already configured in your SCCM/Parallels Mac Management installation. If you are not using Apple DEP, you need to install and configure a Parallels MDM Server. Please read below for more information.

Parallels MDM Server: An MDM server is a required component in a Mobile Device Management implementation. Parallels MDM Server implements management features for Mac computers and makes them available in SCCM through Parallels Mac Management integration.

The computer on which you'll be installing Parallels MDM Server must meet the following requirements:

- Must be accessible from the server where the Parallels Proxy is installed.
- Must be accessible from the Internet.
- For increased security, the server should be located in DMZ.

Parallels MDM Server is installed using the Parallels Mac Management Installation Wizard. After the installation, it must be configured using the Parallels MDM Server Configuration Wizard, which starts automatically after the installation. (You can also launch the configuration wizard manually from the Start menu.)

Wipe a DEP-Enabled Mac Computer

A DEP-enabled Mac computer is enrolled in Parallels MDM service automatically; no additional deployment or configuration steps are necessary. The diagram below shows a standard DEP deployment scenario as described in the Apple DEP Support chapter (page 16). When everything is configured for Apple DEP as required, you can use the lock/wipe feature out of the box.

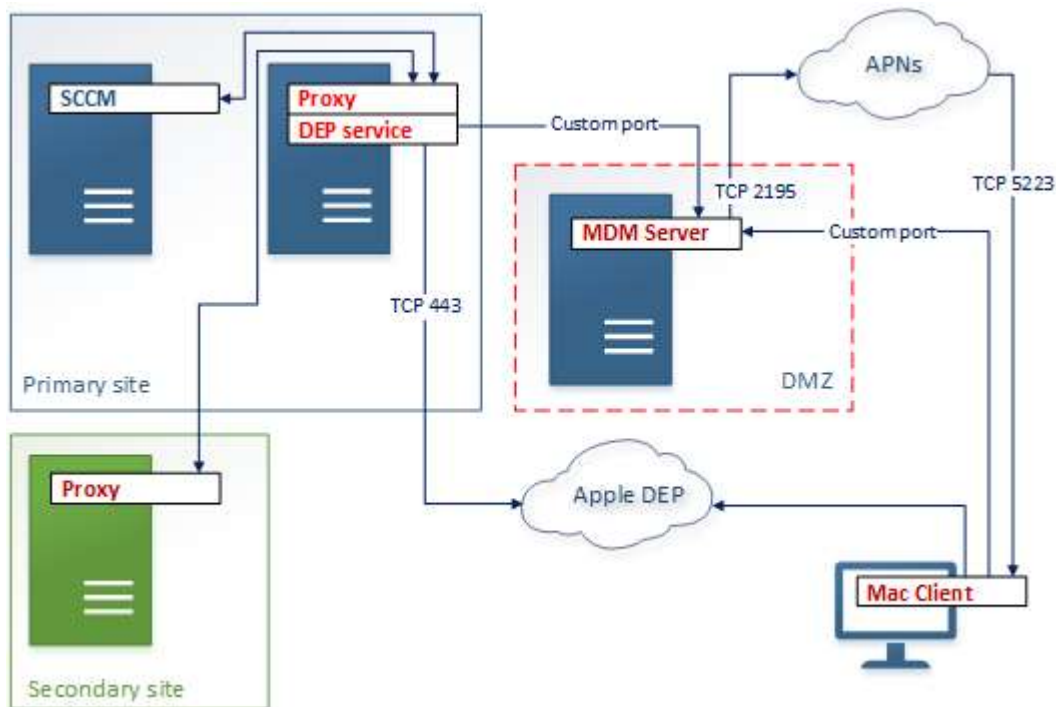

Wipe a Non-DEP Mac Computer

To use the lock/wipe feature on non-DEP Mac computers, you need to enroll them in Parallels MDM service first.

- 1 In the Configuration Manager console, navigate to Administration / Overview / Parallels Mac Management / Mobile Device Management / MDM Links.
- 2 Right-click an MDM Link entry and choose Enrollment Properties. The MDM Enrollment Properties dialog opens.
- 3 Select the “Enable automatic enrollment of Macs into Parallels MDM service” option, and then select one of the following:

- “Enroll all Mac resources.” All Mac computers that are enrolled in SCCM will be automatically enrolled in MDM. (Computers that are already enrolled in MDM as part of DEP are excluded.)
- “Enroll Mac resources from the following collections.” Only the Mac resources from the specified collection(s) will be enrolled. Select this option and click the [+] icon to select a collection and add it to the list. (You can add more than one collection.)

4 Click OK to save automatic MDM enrollment settings and close the dialog.

The next time a Mac computer requests policy updates, it will receive enrollment settings and will be automatically enrolled in the Parallels MDM service.

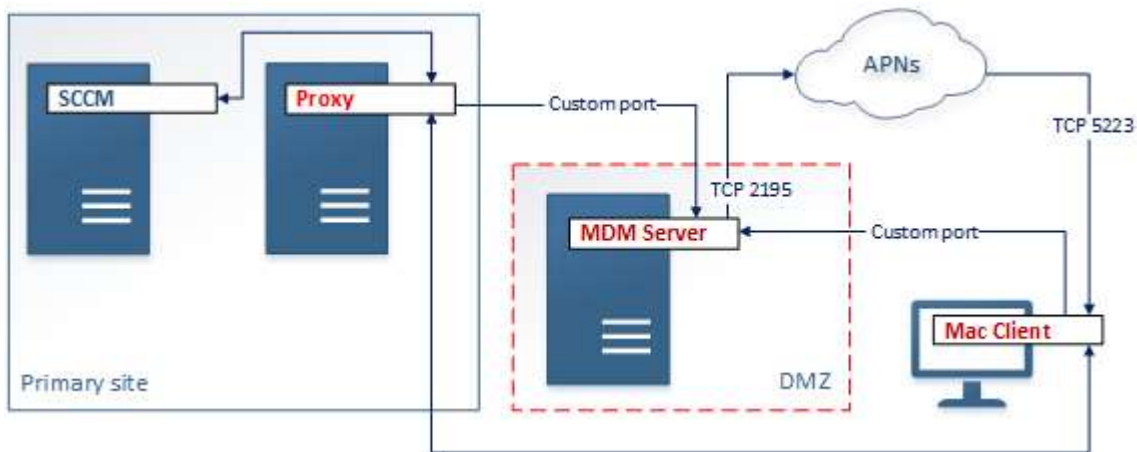

On the diagram above, the Parallels MDM Server uses Apple Push Notification Service (APNs) to send MDM push notifications to Mac computers. Establishing this communication is one of the steps you have to complete when you run the Parallels MDM Server Configuration Wizard. The process involves obtaining a certificate signing request from Parallels My Account, uploading it to the Apple Push Certificates Portal, and obtaining an APNs certificate file from it. Finally, the certificate file is added to the Parallels MDM Server, thus enabling APNs functions on it.

Port numbers that are specified on the diagram above (TCP 5223 and TCP 2195) are used to communicate with APNs and cannot be changed. Port numbers that are labeled as "Custom port" are configured when you run the Parallels MDM Server Configuration Wizard. There are no default port numbers, so you have to select them yourself according to your requirements. Please also see Table 1 below for the list of ports shown on the diagram. All of these ports must be opened for communication.

Table 1: Communication ports used in Parallels Mac Management MDM deployment

Source	Destination	Port	Details
Parallels MDM Server	Apple Push Notification Service (APNs) gateway.push.apple.com	TCP 2195	Used to send notifications to APNs
Mac computer	Apple Push Notification Service (APNs)	TCP 5223	Used to communicate with APNs

CHAPTER 6

	gateway.push.apple.com		
Server hosting Parallels Proxy	Parallels MDM Server	Custom	You select a port number when you configure Parallels MDM Server.
Mac computer	Parallels MDM Server	Custom	You select a port number when you configure Parallels MDM Server

Pre-Installation Checklist

Use the following checklist to help prepare your environment for the deployment of Parallels Mac Management. The Reference column contains links to topics describing how to accomplish a corresponding task. All page number are in reference to the [Parallels Mac Management for Microsoft SCCM Administrator's Guide](#).

	Category	Task	Reference
<input type="checkbox"/>	General requirements	Check the requirements for supported SCCM, Windows, and macOS versions.	General Requirements (page 12)
<input type="checkbox"/>	Parallels Proxy	The Distribution Point Role configuration	Distribution Point Role Configuration (page 13)
<input type="checkbox"/>	Parallels Proxy	Verify the IIS settings on the Distribution Point server	IIS Settings on the Distribution Point Server (page 13)
<input type="checkbox"/>	Parallels Proxy	Configuration Manager Boundaries	Configuration Manager Boundaries Configuration (page 25)

<input type="checkbox"/>	Parallels Proxy	Configure Windows firewall	Configuring Windows Firewall (page 26)
<input type="checkbox"/>	Parallels Proxy	Configure macOS firewall	Configuring macOS Firewall (page 61)
<input type="checkbox"/>	Parallels Proxy	Verify the network environment configuration	Network Configuration (page 13)
<input type="checkbox"/>	Parallels Proxy	Check date and time synchronization	Date and Time Synchronization (page 14)
<input type="checkbox"/>	Parallels NetBoot Server	Optional component. Needed for the macOS image deployment functionality.	Parallels NetBoot Server Requirements (page 14)
<input type="checkbox"/>	Parallels OS X Software Update Point	Optional component. Needed for the macOS software update functionality.	Parallels OS X Software Update Point Requirements (page 15)
<input type="checkbox"/>	Parallels MDM Server	Optional component. Needed for the Apple DEP functionality and the Remote Wipe and Lock feature.	Parallels MDM Server Requirements (page 15)
<input type="checkbox"/>	Other	Verify Reporting Point Role. Optional but needed to view reports.	The Reporting Functionality Requirements (page 17)
<input type="checkbox"/>	Other	Verify Report Viewer. Optional but needed to view reports.	The Reporting Functionality Requirements (page 17)
<input type="checkbox"/>	Other	Review the ports used by Parallels Mac Management	Communication Ports and Protocols (page 17)
<input type="checkbox"/>	User rights	Verify user rights requirements. Note: This is a very important step to ensure a successful installation.	User Rights Requirements (page 18) The KB article at kb.parallels.com/121569 provides additional information on how to set up a service account for proper PMM installation.
<input type="checkbox"/>	PKI integration	Optional, but needed if you would like to integrate Parallels Mac Management with a Public Key Infrastructure (PKI).	Integrating Parallels Mac Management with PKI (page 27)

Installation Requirements

Before proceeding, please read the subsequent sections to learn about system requirements for installing Parallels Mac Management for Microsoft SCCM. The topics include general requirements and requirements for installing individual Parallels Mac Management components.

General Requirements

Supported SCCM versions: At the time of this writing, Parallels Mac Management has been tested with Microsoft System Center Configuration Manager 2012 R2 up to SCCM 1706.

For the most up-to-date information about supported SCCM versions, please see kb.parallels.com/124197

Top-level domain requirement: Parallels Mac Management supports top-level domain structures only (for example, .com, .edu, .mil, .gov, and .net). Pseudo-top-level domains (for example, .local) are NOT supported.

Supported Windows versions: Windows components of Parallels Mac Management follow the same system requirements as the Microsoft System Center components.

Supported macOS versions: macOS 10.7–10.13 are supported.

Index

A

Apple DEP Support – 16

C

Components Overview – 5

D

Deploying Parallels NetBoot Server – 10

Deploying to a Central Administration Site – 9

Deploying to a Primary Site – 8

Deploying to a Primary Site with Secondary Sites – 8

Deploying to a Secondary Site – 8

Deploying to a Standalone SCCM Site – 7

Deployment Configurations – 7

Download Updates from a Local Update Server – 14

Download Updates from Apple Servers – 13

G

Glossary – 4

I

Installing Parallels Configuration Manager Proxy – 8

Installing Parallels Console Extensions – 8

Introduction – 4

M

macOS Software Update Management – 12

O

One MDM Server Serving One SCCM Site – 17

P

Pre-Installation Checklist – 22

R

Remote Lock and Wipe – 19

Required Components – 12, 16, 19

Restrict Which Updates a Mac User Can Install – 14

S

Solution Overview – 5

W

Wipe a DEP-Enabled Mac Computer – 20

Wipe a Non-DEP Mac Computer – 20